

AP Physics 1 Summer Work 2017

The exercises below are a review of the prerequisite math skills that you need to succeed in AP Physics 1. Make sure to read all directions throughout the packet. All work must be completed on the pages below in the area provide. Calculators should not be used. Final answers can be in fractions and in terms of mathematical constants (π , e , i , etc.).

Your work must be legible and linear, and I must be able to follow it easily. Please no incoherent jumping around the page. Mark your final answers by either circling or boxing them. Your completed summer work is due the first day of class.

Do not copy work from another student for your own integrity and for your own benefit. Use a math book or internet for reference. No physics is needed for this packet. If you have difficulty, please do not hesitate to email me at mdipaolo@twpunionschools.org

JOIN THE SUMMER GOOGLE CLASSROOM: ndht00

Significant Figures and Scientific Notation Review

1.) How many significant figures do the following numbers have?

- a.) 6.001 Answer: _____ d.) 27.00 Answer: _____
b.) 0.0080 Answer: _____ e.) π Answer: _____
c.) 206,000 Answer: _____

Directions: Find the following. Final answers should be in scientific notation with the correct number of significant figures.

- 2.) $(5.0 \times 10^{-8})(2.9 \times 10^2)$ 3.) $(3.25 \times 10^4 + 7.4 \times 10^3)$

4.) $6.000 \times 10^{-11} \frac{1.00 \times 10^{26}}{2.00 \times 10^7}$

5.) $\frac{8400}{1.2 \times 10^7}$

Unit Conversions Review

6.) Finish the SI prefix table below. Follow the example of the centi- prefix. You will need to memorize these.

Symbol	Name	Numerical Equivalent
n		
μ		
m		
c	centi	10^{-2}
k		
M		
G		

7.) 16.7 kilograms is how many grams?

8.) 560 nm is how many meters?

9.) 15 years is how many seconds?

10.) 8.99×10^9 seconds is how many years?

11.) 2.998×10^8 m/s is how many kilometers per hour?

Trigonometry Review

Directions: Use the figure below to answer problems 15-25. Simplify as much as you can.

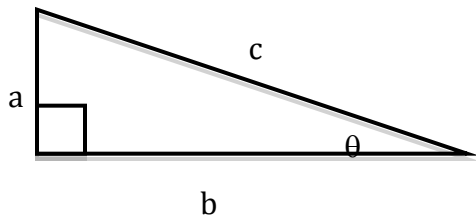

12.) Find c if given a and b .

13.) Find a if given b and c .

14.) Find a if given c and θ .

15.) Find b if given a and θ .

16.) Find c if given b and θ .

17.) Find θ if given b and c .

18.) Find θ if given a and b .

19.) If $a = 2.0$ and $c = 7.0$, what is b ?

20.) If $c = 10.0$ and $\theta = 60^\circ$, what is b ?

21.) If $a = 12.0$ and $\theta = 30^\circ$, what is b ?

22.) Using the properties of triangles, prove that $\angle A \cong \angle C$ in the drawing below.

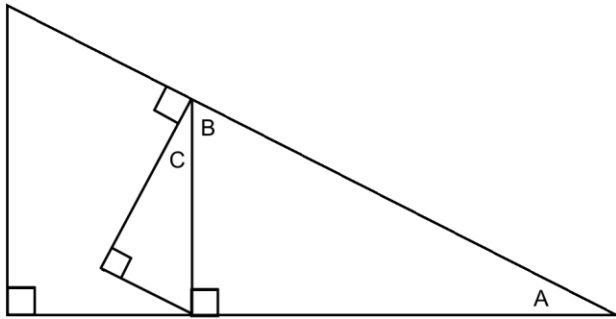

Answer:

23.) For what angles (in degrees) does $\sin \theta \approx \theta$? Describe why mathematically.

24.) Complete the table below without using a calculator.

θ	0°	30°	45°	60°	90°
$\sin \theta$					
$\cos \theta$					
$\tan \theta$					

25.) 360 degrees = _____ radians.

26.) 4.5 revolutions = _____ radians.

27.) Find the length of an arc with a radius of 6.0 m swept across 2.5 radians.

28.) Find the length of an arc with a radius of 10.0 m swept across 100 degrees.

Algebra Review

Directions: Solve the following equations for the given variable and conditions. Simplify if needed.

Example: $2x + xy = z$. Solve for x .

$$x(2 + y) = z$$

$$x = \frac{z}{2 + y}$$

29.) $v_1 + v_2 = 0$. Solve for v_1 .

30.) $a = \frac{v}{t}$. Solve for t .

31.) $v_f^2 = v_i^2 + 2ad$

A.) Solve for v_i .

B.) Solve for d .

32.) $d_f = d_i + v_o t + \frac{1}{2} a t^2$

A.) Solve for v_o .

B.) Solve for t , if $v_o = 0$.

C.) Solve for t , if $d_i = d_f$.

33.) $F = m \frac{v_f - v_i}{t_f - t_i}$

A.) Solve for v_f if $t_i = 0$.

B.) Solve for t_f if $v_f = 0$ and $t_i = 0$.

34.) $a_c = \frac{v^2}{r}$. Solve for v .

35.) $mg \sin \theta = mmg \cos \theta$. Solve for θ .

36.) $\frac{1}{2}mv_f^2 + mgh_f = \frac{1}{2}mv_i^2 + mgh_i$

A.) Solve for h_f if $h_i = 0$ and $v_f = 0$.

B.) Solve for v_f if $h_f = 0$.

37.) $Ft = mv_f - mv_i$. Solve for v_f .

38.) $m_1v_{i,1} + m_2v_{i,2} = (m_1 + m_2)v_f$. Solve for $v_{i,2}$.

39.) $m_1v_{i,1} + m_2v_{i,2} = m_1v_{f,1} + m_2v_{f,2}$. Solve for $v_{f,2}$ if $v_{i,1} = 0$.

40.) $(F_1 \sin \theta)r_1 + (-F_2 \sin \theta)r_2 = 0$. Solve for r_2 .

41.) $-kx + m(-g) = 0$. Solve for m .

42.) $F_g = G \frac{m_1 m_2}{r^2}$. Solve for r .

43.) $L - L \cos \theta = \frac{v^2}{2}$ Solve for L .

44.) $\frac{mv^2}{R} = G \frac{Mm}{R^2}$. Solve for v .

45.) $T = 2\pi \sqrt{\frac{L}{g}}$. Solve for g .

46.) $\frac{1}{2}mv_f^2 + \frac{1}{2}kx^2 = \frac{1}{2}mv_i^2 + mgh_i$. Solve for x if $v_f = 0$.

47.) $\frac{1}{R_T} = \frac{1}{R_1} + \frac{1}{R_2}$. Solve for R_T .

Miscellaneous

Directions: Simplify without using a calculator. Remember to show all of your work.

48.) $\frac{1}{4} + \frac{1}{6}$

49.) $\frac{1}{3} + \frac{1}{18}$

50.) Consider $z = \frac{x}{y}$, $c = ab$, $l = m - n$, or $r = \frac{s^2}{t^2}$.

a.) As x increases and y stays constant, z _____.

b.) As y increases and x stays constant, z _____.

c.) As x increases and z stays constant, y _____.

d.) As a increases and c stays constant, b _____.

e.) As c increases and b stays constant, a _____.

f.) As b increases and a stays constant, c _____.

g.) As n increases and m stays constant, l _____.

h.) As l increases and n stays constant, m _____.

i.) If s is tripled and t stays constant, r is multiplied by _____.

j.) If t is doubled and s stays constant, r is multiplied by _____.

Systems of equations

Conceptual Question:

51.) How many equations are needed to solve...

- a.) for 1 unknown variable? _____
- b.) for 2 unknown variables? _____
- c.) for 3 unknown variables? _____

Use the equations in each problem to solve for the specified variable in the given terms. Simplify.

52.) $F_f = mF_N$ and $F_N = mg\cos\theta$. Solve for μ in terms of F_f , m , g , and θ .

53.) $F_1 + F_2 = F_T$ and $F_1 \times d_1 = F_2 \times d_2$. Solve for F_1 in terms of F_T , d_1 , and d_2 .

54.) $F_c = ma_c$ and $a_c = \frac{v^2}{r}$. Solve for r in terms of F_c , m , and v .

55.) $T = 2\pi\sqrt{\frac{L}{g}}$ and $T = \frac{1}{f}$. Solve for L in terms of π , g , and f .

Graphing Equations

56.) If $r = c - x*t$ was graphed on an r vs. t graph, what would the following be?
Slope: _____ y-intercept: _____

57.) On the y vs. x graphs below, sketch the relationships given.

a.) $y = mx + b$, if $m > 0$ and $b = 0$.

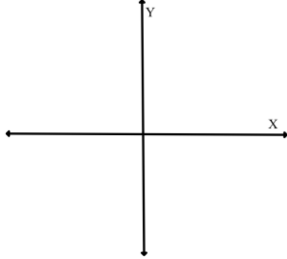

b.) $y = mx + b$, if $m < 0$ and $b > 0$.

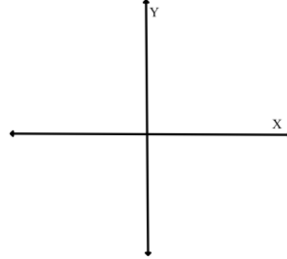

c.) $y = x^2$

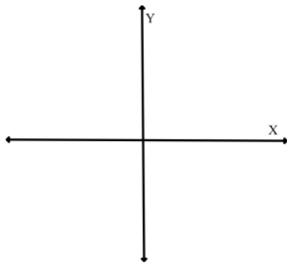

d.) $y = \sqrt{x}$

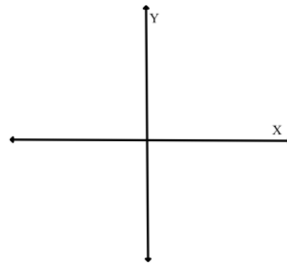

e.) $y = 1/x$

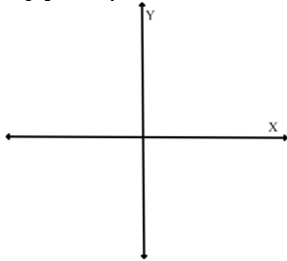

f.) $y = 1/x^2$

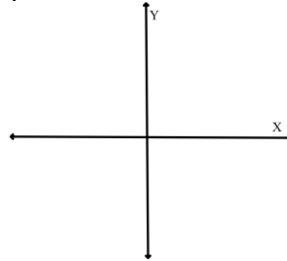

g.) $y = \sqrt{\frac{1}{x}}$

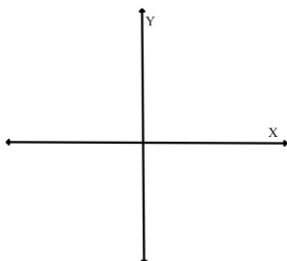

h.) $y = \sin(x)$

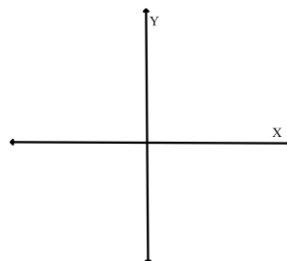

Marbles in Cylinder Lab

You received a graduated cylinder with three identical marbles and an unknown amount of water already in it. You placed extra identical marbles in the cylinder and obtained the data below. Use the data to graph a best-fit line showing the relationship between the water level and the number of marbles. The y-intercept should be visible on the graph. Label your axes and include units.

From the graph, determine a mathematical formula for the water level for any number of marbles. Lastly, give an explanation of your formula in words. Make sure to give an explanation of the slope and y-intercept of your formula.

Number of Marbles in Water	Water level (mL)
3	58
4	61
5	63
6	65
7	68

58.) Graph below

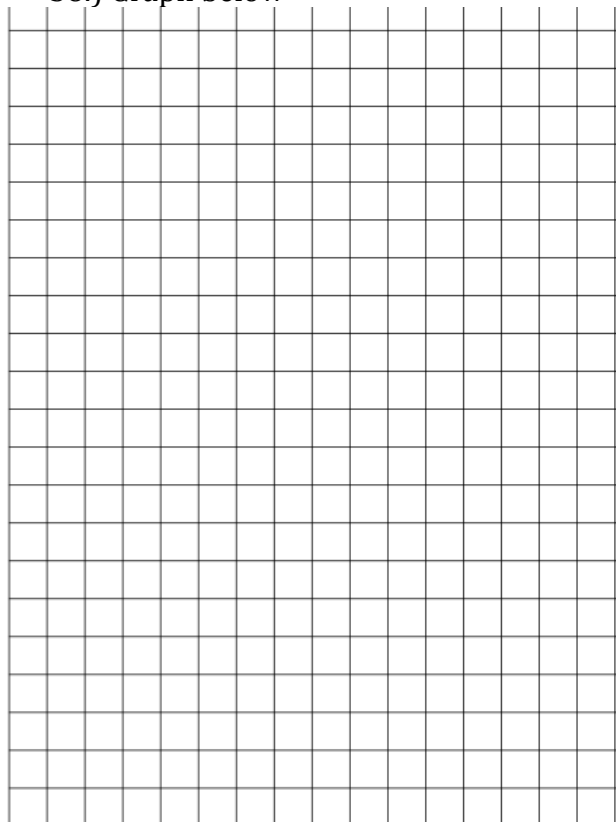

59.) Formula: _____

60.) Explanation of the formula in words: (Include the meaning of the slope and y-intercept.)